

GATE: 2002

CE: CIVIL ENGINEERING

SECTION A. (75 Marks)

1. This question consists of TWENTY FIVE sub-questions (1.1-1.25) of ONE mark each. For each of these sub-questions four possible answers (A, B, C and D) are given, out of which ONLY ONE is correct.

1.1. Eigen values of the following matrix are: $\begin{bmatrix} -1 & 4 \\ 4 & -1 \end{bmatrix}$

- (A) 3 and - 5
(B) - 3 and 5

- (C) - 3 and - 5
(D) 3 and 5

1.2. The value of the following definite integral is: $\int_{-\frac{\pi}{2}}^{\frac{\pi}{2}} \frac{\sin 2x}{1+\cos x} dx$

- (A) - 2 ln 2
(B) 2

- (C) 0
(D) $(\ln 2)^2$

1.3. The following function has a local minima at which value of x

$$f(x) = x\sqrt{5 - x^2}$$

- (A) $-\frac{\sqrt{5}}{2}$
(B) $\sqrt{5}$

- (C) $\sqrt{\frac{5}{2}}$
(D) $-\sqrt{\frac{5}{2}}$

1.4. For the loading given in the figure below, two statements (I and II) are made.

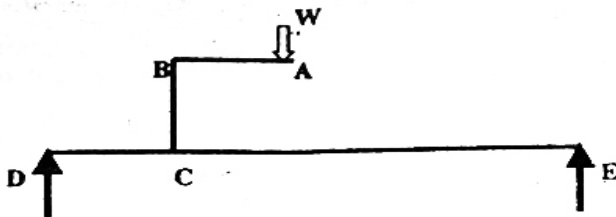

- I. Member AB carries shear force and bending moment
II. Member BC carries axial load and shear force.

Which of the following is true?

- (A) Statement I is true but II is false
(B) Statement I is false but II is true

- (C) Both statements I and II are true
(D) Both statements I and II are false

1.5. Read the following two statements

- I. Maximum strain in concrete at the outermost compression fibre is taken to be 0.0035 in bending
- II. The maximum compressive strain in concrete in axial compression is taken as 0.002.

Keeping the provisions of IS 456-2000 on limit state design in mind, which of the following is true?

- (A) Statement I is true but II is false
(B) Statement I is false but II is true
(C) Both statements I and II are true
(D) Both statement I and II are false

1.6. As per the provisions of IS 456-2000, the (short term) modulus of elasticity of M25 grade concrete (in N/mm^2) can be assumed to be

- (A) 25000
(B) 28500
(C) 30000
(D) 36000

1.7. The shear modulus (G), modulus of elasticity (E) and the Poisson's ratio (ν) of a material are related as,

- (A) $G = E/[2(1 + \nu)]$
(B) $E = G/[2(1 + \nu)]$
(C) $G = E/[2(1 - \nu)]$
(D) $G = E/[2(\nu - 1)]$

1.8. When designing steel structures, one must ensure that local buckling in webs does not take place. This check may not be very critical when using rolled steel sections because.

- (A) Quality control at the time of manufacture of rolled sections is very good
(B) Web depths available are small
(C) Web stiffeners are in-built in rolled sections
(D) Depth to thickness ratios (of the web) are appropriately adjusted

1.9. An ISMB 500 is used as a beam in a multi-storey construction. From the viewpoint of structural design, it can be considered to be 'laterally restrained' when,

- (A) The tension flange is 'laterally restrained'
(B) The compression flange is 'laterally restrained'
(C) The web is adequately stiffened
(D) The conditions in (A) and (C) are met

1.10. Data from a sieve analysis conducted on a given sample of soil showed that 67% of the particles passed through 75 micron IS sieve. The liquid limit and plastic limit of the finer fraction was found to be 45 and 33 percents respectively. The group symbol of the given soil as per IS: 1498-1970 is

- (A) SC (C) CH
 (B) MI (D) MH

1.11. The void ratios at the densest, loosest and the natural states of a sand deposit are 0.2, 0.6 and 0.4, respectively. The relative density of the deposit is

- (A) 100% (C) 50%
 (B) 75% (D) 25%

1.12. The following data were obtained from a liquid limit test conducted on a soil sample.

Number of blows	17	22	25	28	34
Water content (%)	68.3	63.1	61.9	60.6	60.5

The liquid limit of the soil is

- (A) 63.1 % (C) 61.9 %
 (B) 62.8 % (D) 60.6 %

1.13. The specific gravity and insitu void ratio of a soil deposit are 2.71 and 0.85 respectively. The value of the critical hydraulic gradient is

- (A) 0.82 (C) 0.92
 (B) 0.85 (D) 0.95

1.14. The observed value of the standard penetration number (N) at 10m depth of a silty sand deposit is 13. The unit weight of the soil is 16 kN/m^3 . The N value after correcting for the presence of fines will be

- (A) 12 (C) 14
 (B) 13 (D) 15

1.15. The force 'F' required at equilibrium on the semi-cylindrical gate shown below is

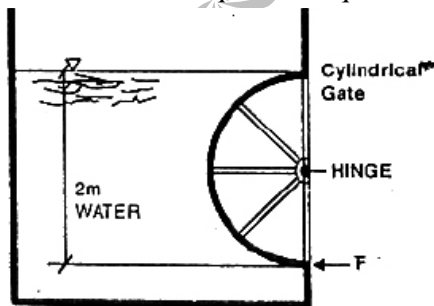

- (A) 9.81 kN (C) 19.62 kN
 (B) 0.0 kN (D) None of the above

- 1.16. Velocity distribution in a boundary layer flow over a plate is given by
 $(u/u_m) = 1.5 \eta$
where, $\eta = y/\delta$; y is the distance measured normal to the plate; δ is the boundary layer thickness; and u_m is the maximum velocity at $y = \delta$. If the shear stress τ , acting on the plate is given by
 $\tau = K(\mu u_m)/\delta$
where, μ is the dynamic viscosity of the fluid, K takes the value of
(A) 0 (C) 1.5
(B) 1 (D) None of the above
- 1.17. A 9-hour Unit Hydrograph (UH) of a catchment is triangular in shape with a total time base of 36 hours and a peak discharge of $18 \text{ m}^3/\text{s}$. The area of the catchment (in sq. km) is
(A) 233 (C) 1.2
(B) 117 (D) Sufficient information not available
- 1.18. When there is an increase in the atmospheric pressure, the water level in a well penetrating in a confined aquifer
(A) Increases
(B) Decreases
(C) May increase or decrease depending on the nature of the aquifer
(D) Does not undergo any change
- 1.19. In a domestic wastewater sample, COD and BOD were measured. Generally which of the following statement is true for their relative magnitude?
(A) COD = BOD (C) COD < BOD
(B) COD > BOD (D) Nothing can be said
- 1.20. In disinfection, which of the following forms of chlorine is most effective in killing the pathogenic bacteria?
(A) Cl (C) NH_2Cl
(B) OCl (D) HOCl
- 1.21. A trickling filter is designed to remove
(A) Settleable Solids (C) Dissolved Organic Matter
(B) Colloidal Solids (D) None of the above
- 1.22. In natural water, hardness is mainly caused by
(A) Ca^{++} and Mn^{++} (C) Na^+ and K^+
(B) Ca^{++} and Fe^{++} (D) Ca^{++} and Mg^{++}

- 1.23. Bitumen is derived from
- (A) Destructive distillation of coal tar
(B) Destructive distillation of petroleum
(C) Fractional distillation of petroleum
(D) Naturally occurring ores
- 1.24. Dowel bars in concrete pavement are placed
- (A) Along the direction of traffic
(B) Perpendicular to the direction of traffic
(C) Along 45° to the direction of traffic
(D) Can be placed along any direction
- 1.25. Stopping sight distance and frictional co-efficients are
- (A) Directly proportional to each other
(B) Inversely proportional to each other
(C) Unrelated
(D) Either directly or inversely proportional to each other depending on the nature of pavement
2. This question consists of TWENTY FIVE sub-questions (2.1 – 2.25) of TWO marks each. For each of these sub-questions four possible answers (A, B, C and D) are given, out of which only one is correct. Answer each sub-question by darkening the appropriate bubble on the OBJECTIVE RESPONSE SHEET (ORS) using a soft HB pencil. Do not use the ORS for any rough work. You may use the Answer Book for any rough work, if needed.
- 2.1. The value of the following improper integral is $\int_0^1 x \ln x$
- (A) $1/4$
(B) 0
(C) $-1/4$
(D) 1
- 2.2. The directional derivative of the following function at $(1, 2)$ in the direction of $(4i + 3j)$ is $f(x,y) = x^2 + y^2$
- (A) $4/5$
(B) 4
(C) $2/5$
(D) 1
- 2.3. The Laplace Transform of the following function is $f(t) = \begin{cases} \sin t & \text{for } 0 \leq t \leq \pi \\ 0 & \text{for } t > \pi \end{cases}$
- (A) $\frac{1}{1+s^2}$ for all $s > 0$
(B) $\frac{1}{1+s^2}$ for all $s < \pi$
(C) $\frac{1+e^{-\pi s}}{1+s^2}$ for all $s > 0$
(D) $\frac{e^{-\pi s}}{1+s^2}$ for all $s > 0$

2.4. The limit of the following sequence as $n \rightarrow \infty$ is

- (A) 0
(B) 1
(C) ∞
(D) $-\infty$

2.5. A steel beam (with a constant EI, and span L) is fixed at both ends and carries a uniformly distributed load (w kN/m), which is gradually increased till the beam reaches the stage of plastic collapse (refer to the following figure). Assuming 'B' to be at mid-span, which of the following is true,

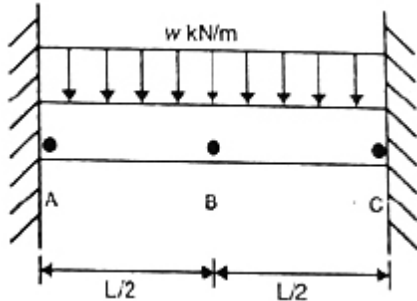

- (A) Hinges are formed at A, B and C together.
(B) Hinges are formed at B and then at A and C together
(C) Hinges are formed A and C together and then at B
(D) Hinges are formed at A and C only
- 2.6. As per the provisions of IS 456-2000, in the limit state method for design of beams, the limiting value of the depth of neutral axis in a reinforced concrete beam of effective depth 'd' is given as
(A) 0.53d
(B) 0.48d
(C) 0.46d
(D) Any of the above depending on the different grades of steel
- 2.7. ISA 100 × 100 × 10 mm (Cross sectional area = 1908 mm²) serves as tensile member. This angle is welded to a gusset plate along A and B appropriately as shown. Assuming the yield strength of the steel to be 260 N/mm² the tensile strength of this member can be taken to be approximately,

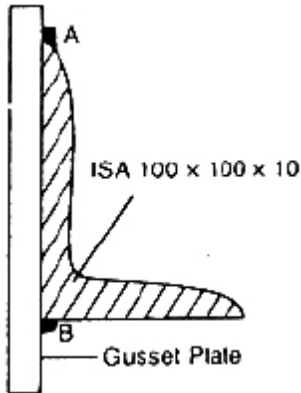

- (A) 500 kN
 (B) 300 kN
 (C) 225 kN
 (D) 375 kN

2.8. ISA $100 \times 100 \times 10$ mm (Cross sectional area = 1908 mm^2) is welded along A and B (Refer to figure for question 2.7), such that the lengths of the weld along A and B are l_1 and l_2 , respectively. Which of the following is a possibly acceptable combination of l_1 and l_2

- (A) $l_1 = 60 \text{ mm}$ and $l_2 = 150 \text{ mm}$
 (B) $l_1 = 150 \text{ mm}$ and $l_2 = 60 \text{ mm}$
 (C) $l_1 = 150 \text{ mm}$ and $l_2 = 150 \text{ mm}$
 (D) Any of the above, depending on the size of the weld

2.9. In the propped cantilever beam carrying a uniformly distributed load of $w \text{ N/m}$, shown in the following figure, the reaction at the support B is

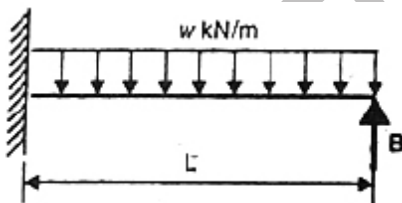

- (A) $\frac{5}{8} wL$
 (B) $\frac{3}{8} wL$
 (C) $\frac{1}{2} wL$
 (D) $\frac{3}{4} wL$

2.10. An infinite slope is to be constructed in a soil. The effective stress strength parameters of the soil are $c' = 0$ and $\phi' = 30^\circ$. The saturated unit weight of the slope is 20 kN/m^3 and the unit weight of water is 10 kN/m^3 . Assuming that seepage is occurring parallel to the slope, the maximum slope angle for a factor of safety of 1.5 would be

- (A) 10.89° (C) 12.48°
(B) 11.30° (D) 14.73°
- 2.11. If the effective stress strength parameters of a soil are $c' = 10\text{kPa}$ and $\phi' = 30^\circ$, the shear strength on a plane within the saturated soil mass at a point where the total normal stress is 300kPa and pore water pressure is 150 kPa will be
(A) 90.5 kPa. (C) 101.5 kPa
(B) 96.6 kPa. (D) 105.5 kPa
- 2.12. The time for a clay layer to achieve 85% consolidation is 10 years. If the layer was half as thick, 10 times more permeable and 4 times more compressible then the time that would be required to achieve the same degree of consolidation is
(A) 1 year (C) 12 years
(B) 5 years (D) 16 years
- 2.13. In a triaxial test carried out on a cohesionless soil sample with a cell pressure of 20 kPa, the observed value of applied stress at the point of failure was 40 kPa. The angle of internal friction of the soil is
(A) 10° (C) 25°
(B) 15° (D) 30°
- 2.14. In a falling head permeability test the initial head of 1.0m dropped to 0.35 m in 3 hours, the diameter of the stand pipe being 5 mm. The soil specimen was 200 mm long and of 100 mm diameter. The coefficient of permeability of the soil is:
(A) $4.86 \times 10^{-5} \text{ cm/s}$ (C) $4.86 \times 10^{-7} \text{ cm/s}$
(B) $4.86 \times 10^{-6} \text{ cm/s}$ (D) $4.86 \times 10^{-8} \text{ cm/s}$
- 2.15. In a lined rectangular canal, the Froude number of incoming flow is 3.0. A hydraulic jump forms when it meets the pool of water. The depth of flow after the jump formation is 1.51 m. Froude number of flow after the hydraulic jump is
(A) 0.30 (C) 0.41
(B) 0.71 (D) None of these
- 2.16. A pump can lift water at a discharge of $0.15 \text{ m}^3/\text{s}$ to a head of 25 m. The critical cavitation number (σ_c) for the pump is found to be 0.144. The pump is to be installed at a location where the barometric pressure is 9.8 m of water and the vapour pressure of water is 0.30 of water. The intake pipe friction loss is 0.40 m. Using the minimum value of NPSH (Net Positive Suction Head), the maximum allowable elevation above the sump water surface at which the pump can be located is

- (A) 9.80 m (C) 5.50 m
(B) 6.20 m (D) None of the above
- 2.17. During a 6-hour storm, the rainfall intensity was 0.8 cm/hour on a catchment of area 8.6 km². The measured runoff volume during this period was 2,56,000 m³. The total rainfall was lost due to infiltration, evaporation, and transpiration (in cm/hour) is
(A) 0.80 (C) 0.496
(B) 0.304 (D) Sufficient information not available
- 2.18. The rainfall on five successive days in a catchment were measured as 3, 8, 12, 6, and 2 cms. If the total runoff at the outlet from the catchment was 15 cm, the value of the ϕ -index (in mm/hour) is
(A) 0.0 (C) 1.53
(B) 1.04 (D) Sufficient information not available
- 2.19. A canal was designed to supply the irrigation needs of 1200 hectares to land growing rice of 140 days base period having a Delta of 134 cms. If this canal water is used to irrigate wheat of base period 120 days having a Delta of 52 cm, the area (in Hectares) that can be irrigated is
(A) 2650 (C) 543
(B) 3608 (D) None of the above
- 2.20. For a water treatment plant having a flow rate of 432m³/hr, what is the required plan area of a Type I setting tank to remove 90% of the particles having a settling velocity of 0.12 cm/sec is
(A) 120 m² (C) 90 m²
(B) 111 m² (D) 100 m²
- 2.21. The theoretical oxygen demand of a 0.001 mol/L glucose solution is
(A) 180 mg/L (C) 90 mg/L
(B) 192 mg/L (D) 90 mg/L
- 2.22. A wastewater sample has an initial BOD of 222 mg/L. The first order BOD decay coefficient is 0.4/day. The BOD consumed (in mg/L) in 5 days is
(A) 150 (C) 30
(B) 192 (D) 50
- 2.23. A car is moving at a speed of 72 km/hr on a road having 2% upward gradient. The driver applies brakes when he sees an obstruction. If his reaction time is 1.5 seconds, assuming that the co-efficient of friction between the pavement and tyre as 0.15, calculate the distance traversed before the car finally stops.

- (A) 24 m (C) 1056 m
(B) 150 m (D) 324 m

2.24. The average daily traffic on a stretch of road is 300 commercial vehicles per lane per day. Design traffic repetitions for 10 years when vehicle damage factor is 2.5 and traffic growth rate is 7%, is

- (A) 3.8 msa (C) 45.4 msa
(B) 23.5 msa (D) 16 msa

2.25. In a concrete pavement

- A. Temperature stress is tensile at bottom during day time
B. Load stress is compressive at bottom

- (A) Both the statement A and B are correct (C) Statement B is wrong and A is correct
(B) Statement A is correct and B is wrong (D) Both statement A and B are incorrect

SECTION B (75 Marks)

This section consists of TWENTY question of five marks each. Any FIFTEEN out of these questions need to be answered on the Answer Book provided.

3. A solid region in the first octant is bounded by the co-ordinate planes and the plane $x + y + z = 2$. The density of the solid is $\rho(x, y, z) = 2x$. Calculate the mass of the solid
(5)

4. The following equation is sometimes used to model the population growth:

$$\frac{dN}{dt} = -aN \left(\ln \frac{N}{K} \right)$$

where, N is the population at time t , $a > 0$ is growth coefficient and $K > 0$ is a constant. Given, at $t = 0$, $N = N_0$ and $0 < N_0 < K$.

(A) Find an expression for the population with time.

(2)

(B) What is the population as $t \rightarrow \infty$?

(1)

(C) Find a constant $c \in (0, 1)$ such that the population growth rate is maximum at $N = cK$.

(2)

5. A schematic representation of a $P_u - M_u$ interaction diagram for the design of reinforced concrete columns is given in the following figure. Based on the given diagram, answer the following question: (1 + 1 + 2 + 1)

(A) What do the points A and C physically signify?

- (B) What is the basic difference between the portions AB and BC?
- (C) In the region BC, why does the moment capacity of the column increase even as the axial load is also being increased?
- (D) Design codes often require the designer to ensure adequate strength for a minimum eccentricity. How is such a provision incorporated into the interaction diagram?

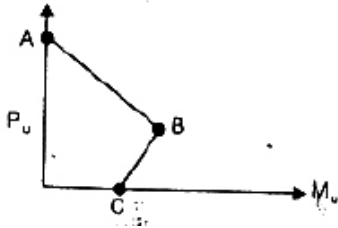

6. The following figure shows a simply supported beam carrying a uniformly distributed load (udl) of 10 kN/m. Assuming the beam to have a rectangular cross-section of 240 mm(b) \times 400 mm (h), draw the state of stress at infinitesimal elements A, B, C and D as shown.

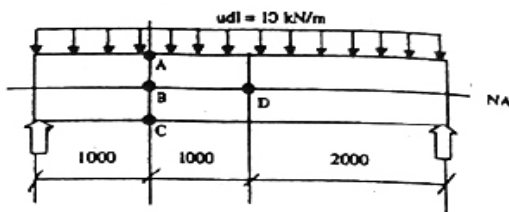

7. Give reasons for the following in not more than 20 words (1 \times 5)
- (A) A maximum permissible distance between lacings and battens in steel columns is usually specified.
- (B) It is sometimes preferable to have unequal flange angles with the longer legs horizontal in a plate girder.
- (C) If two channels sections need to be used as a steel column, they may be connected 'face-to-face' rather than 'back to back'.
- (D) It is sometimes preferred to have a small gap between the web and the flange plate in a plate girder.
- (E) A maximum permissible 'outstand may be specified for flanges in built-up sections.
8. A 10 m long prestressing bed is used to cast 4 (pretensioned) prestressed concrete beams of 2.3 m each. A schematic representation of the bed is given in the following figure. The continuous prestressing reinforcement is pulled at the end 'Y' of the bed through a distance of 20 mm to introduce the required 'prestress', before the concrete is cast. After the concrete has hardened, the prestressing reinforcement is cut at points A, B, C, D and E.

Assuming that the prestress is introduced without eccentricity, what is the loss in prestress on account of elastic deformation of concrete. Assume $E_s = 200,000 \text{ N/mm}^2$, $E_c = 20,000 \text{ N/mm}^2$, Area of prestressing reinforcement is 500 mm^2 , size of beams = $200 \text{ mm (b)} \times 400 \text{ mm (h)}$.

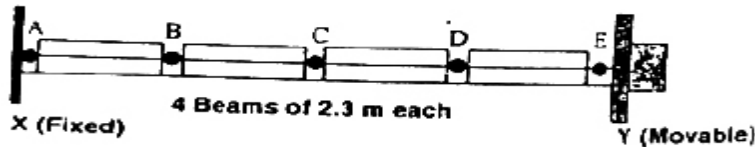

9. Calculate the shape factor for the T-section shown in the following figure made up of two plates $100 \text{ mm} \times 10 \text{ mm}$. What will be the load factor if the permissible stress in bending is only $2/3$ of the yield stress (σ_y)

(4 + 1)

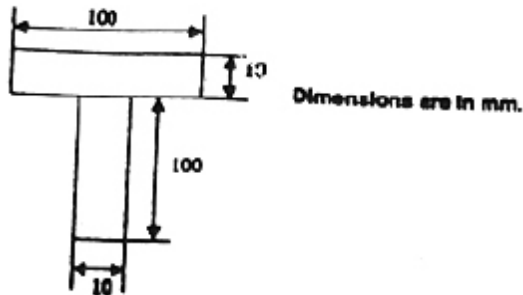

10. Give reasons for the following in not more than 20 words:

(1 × 5)

- (A) A maximum permissible distance between ties in reinforced concrete columns is usually specified
- (B) A concrete mix is targeted to give higher compressive strength than the required characteristic strength.
- (C) In the limit state design of reinforced concrete beams, it is a requirement that the maximum strain in the tension reinforcement in the section at failure is not less than a given value.
- (D) In the case of slabs running over supports, reinforcement needs to be provided on the top in the neighbourhood of the supports.
- (E) The load carrying capacity of an RC column with appropriate helical reinforcement can be taken to be slightly higher than that having lateral ties.
11. Soil has been compacted in an embankment at a bulk density of 2.15 Mg/m^3 and a water content of 12%. The value of specific gravity of soil solids is 2.65. The water table is well below the foundation level. Estimate the dry density, void ratio, degree of saturation and air content of the compacted soil. (5)

12. A retaining wall with a stratified backfill and a surcharge load is shown in the following figure. Draw the earth pressure diagram detailing the values at the critical points. Also estimate the resultant thrust on the wall and its position. (5)

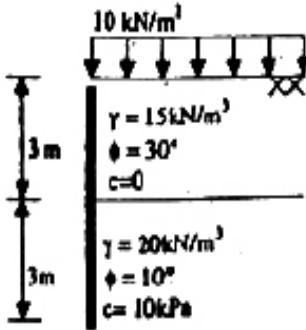

13. A group of 16 piles (diameter = 50 cm, length = 14m, centre to centre spacing = 1m) arrange in a square pattern passes through a recent fill (thickness = 3 m) overlying a soft clay deposit (thickness = 5 m) which is consolidating under the fill load and rests in a stiff clay strata. All the strata are saturated. The soil properties of different strata are (5)

Type of Soil	Unit Weight (γ) (kN/m ³)	Strength Parameters		Adhesion Parameter (α)
		C _u (kPa)	φ _u	
Fill	16	50	0	0.60
Soft Clay	17	20	0	0.40
Stiff Clay	21	70	0	0.45

Estimate the ultimate load carrying capacity (Q₅) of the pile group.

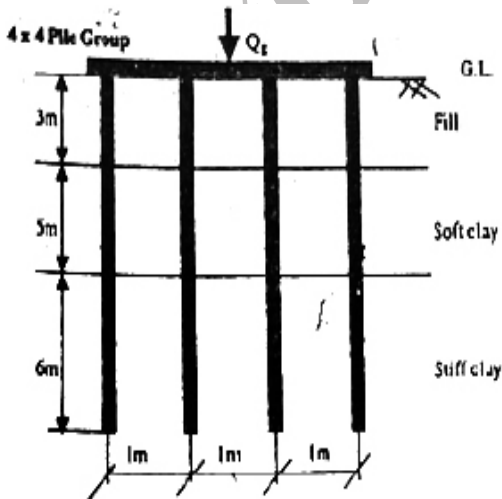

14. A 3 m wide strip foundation is to be constructed on the surface of a silty soil with $c' = 20$ kPa, $\phi' = 30^\circ$ and $\gamma = 18$ kN/m³. The footing is subjected to a vertical load of 200 kN/m run of wall at an eccentricity of 0.25 m together with a horizontal force of 50 kN/m run of wall. Assuming that the water table is well below the foundation level, estimate the ultimate bearing capacity of the foundation. (5)
15. A Francis turbine has an inlet diameter of 2.5 m and an outlet diameter of 1.5 m. The breadth of the blade is constant at 0.20 m. The runner rotates at a speed of 300 rpm with a discharge of 10.0 m³/s. The vanes are radial at the inlet and discharge is radially outwards at the outlet. Calculate the angle of guide vane to be set at the inlet and the blade angle at the outlet. (5)
16. A 30-cm diameter pumping well starts to pump water at 6:00 AM on a day at a rate of 2000 L/min from a confined aquifer (thickness = 30 m, permeability = 30 m/day, and storage coefficient = 0.005). Find out the slope of the hydraulic gradient at 9:00 PM on the same day between the two observation wells located at distance of 50 m and 100 m from the pumping well, respectively. Assume the piezometric surface to be linear between the two observation wells. (5)
17. A and B are two concentration points along a river in a catchment of area 3.5 km². The concentration point A is 1 km down stream of concentration point B. The base flow in the river reach AB is 10 m³/s. A 2-hour rainfall event occurs on this catchment having rainfall intensities of 4 cm/hr during the first hour and 2 cm/hr during the second hour. A 2-hr UH at concentration point B is given below.
- | | | | | | | | | |
|---------------------------------|---|----|----|-----|-----|----|----|----|
| Time (hours) | 0 | 3 | 6 | 9 | 12 | 15 | 18 | 21 |
| UH Ordinate (m ³ /s) | 0 | 25 | 50 | 160 | 110 | 45 | 8 | 0 |
- Compute the ordinates of the flood hydrograph at concentration point A resulting from the 2-hr rainfall event. (Assume ϕ -index = 2cm/hour; Muskingum routing constants $K = 6$ hours and $x = 0.2$).
18. A culturable command area for a distributory is 12,000 hectares. The intensity of irrigation is 90-percent for Rabi and 80-percent for Kharif crop. The outlet factors for Rabi and Kharif crops are 720 ha / cumec and 775 ha / cumec, respectively. Design a lined canal having hydraulically efficient trapezoidal shape with 2 H: IV side slopes and a bed slope of 1 / 5000. Assume Manning's to be 0.014. (5)
19. A city discharges wastewater in a river. The wastewater discharge has a flow rate of 5.0 m³/sec, an ultimate BOD of 49.2 mg/L and DC of 1.6 mg/L. Just upstream from this discharge the river

has a flow of $50 \text{ m}^3 / \text{sec}$, a BOD of 3 mg/L and DO of 6 mg/L (Refer to the following figure). The reaeration coefficient of the river is $0.2 / \text{day}$ and the BOD decay coefficient is $0.4 / \text{day}$. The river flow has a constant cross-section area of 200 m^2 . The saturated DO concentration of the river water may be assumed to be 8.0 mg/L

(A) Calculate the DO of the stream at a point 10 km downstream from the discharge.

(3)

(B) At which point in the downstream will the DO be minimum?

(2)

$$Q_r = 50 \text{ m}^3 / \text{sec}$$

$$\text{BOD}_r = 3 \text{ mg/L}$$

$$\text{DO}_r = 6 \text{ mg/L}$$

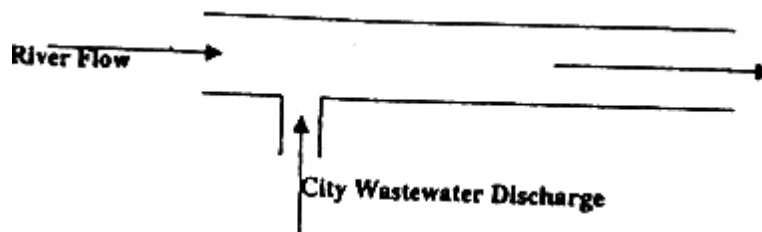

$$Q_d = 5 \text{ m}^3 / \text{sec}$$

$$\text{BOD}_d = 49.2 \text{ mg/L}$$

$$\text{DO}_d = 1.6 \text{ mg/L}$$

20. The following is a chlorination curve for a water sample:

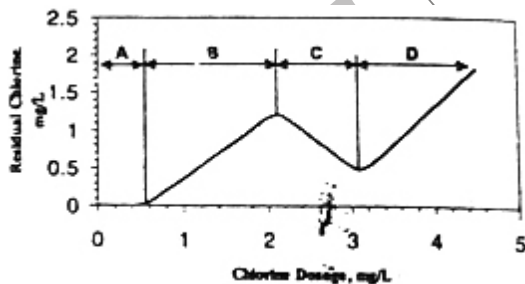

(A) Explain what chlorine does in the regions A, B, C and D?

(1 × 4)

(B) If you are to design a chlorination facility for this water, what minimum chlorine dose will you choose?

21. A vehicle is maneuvering a horizontal curve of radius R with superelevation Q° . Derive the expression for maximum speed beyond which it would overturn outward if the coefficient of

friction between the tyre and the pavement is 'f'. Find the value of this speed if $R = 250$ m, $\theta = 5^\circ$, $f = 0.15$, $h = 1$ and $b = 0.75$ m (Refer to the following figure). (5)

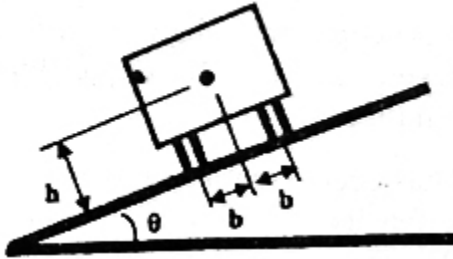

22. The specific gravities and weight proportions for aggregates and bitumen are as under for the preparation of Marshall moulds:

	Weight (gm)	Specific Gravity
Aggregate1	825	2.63
Aggregate2	1200	2.51
Aggregate3	325	2.46
Aggregate4	150	2.43
Bitumen	100	1.05

The volume and weight of one Marshall mould was found to be 475 cc and 1100 gm. Assuming absorption of bitumen in aggregates is zero, find

- (A) Percentage air voids (V_v) (3)
- (B) Percentage bitumen by volume (V_b) (1)
- (C) Percentage and voids in mineral aggregates (VMA) (1)